

Measurement Accuracy: Real Or Imagined



Scott Swinford
Vice President of Engineering
Pacific Instruments, Inc.
Concord, CA

IMAC XXVII
February 2009
Orlando, FL



Measurement Accuracy: Real Or Imagined



Quality Products

- Quality Products Come From Quality Design & Testing.
- Quality Testing Requires Measurement Accuracy.
- Measurement Accuracy Comes From:
 - Decreasing Error Sources
 - Increasing Measurement Resolution
 - Proper Calibration
 - Understanding And Managing All Elements Of The Measurement

Measurement Accuracy: Real Or Imagined



Elements Of A Measurement

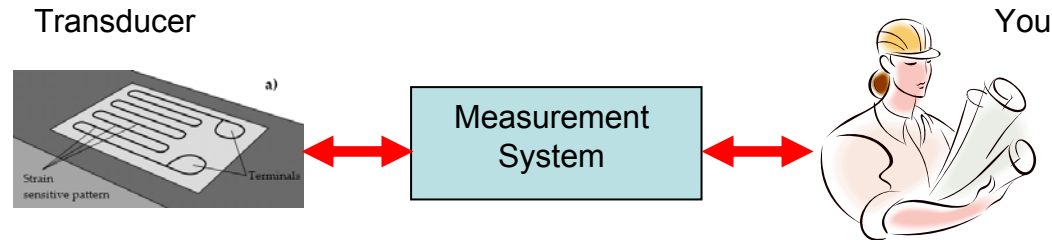

- Simply Stated: A Measurement Is Made Using Very Few Elements.
- The Elements Can Be Complex And They Do Affect Each Other.
- The Best Measurement That Can Be Made Depends On The **Transducer Accuracy**.
- After That, The Best Measurement That Can Be Made Depends On The **Measurement System Accuracy**.
- After That, The Best Measurement That Can Be Made Depends On **What You Do (Or Fail To Do) Properly**.
- If All Goes Well **A Quality Measurement Is Made**.

Measurement Accuracy: Real Or Imagined

Specification Sheets: A Good Starting Point

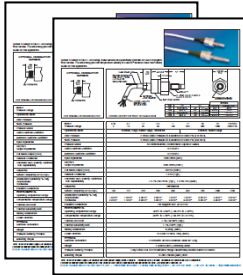

Transducer Specifications



Measurement System Specifications

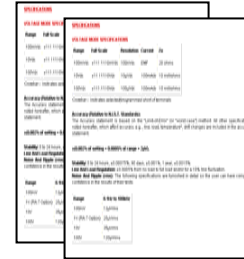

Calibration Standard Specifications

- Specification Sheets Provide Accuracy Information.
- Each Element Involved In The Measurement Needs To Be Considered.
- Beware Of Specsmanship Issues.

Measurement Accuracy: Real Or Imagined



Specsmanship: What Is It?

- Describing An Element's Accuracy Involves Providing Information About All Possible Error Sources.
- There Is No Standard Method Of Reporting This Information.
- SpecsmanSHIP Is The Process Of Reporting The Information In A Fashion Where It Looks Best To The Reader.
- This Can Involve Omitting Critical Details Or Information About How The Error Information Should Be Applied.
- **It Is Not Always A Trick To Deceive You.** It Can Be Due To:
 - Not Wanting Competitors To Know About The Product.
 - Needing To Have More Information About Your Usage Of The Product To Properly Specify The Error.
- **When In Doubt..... Ask About.**

Measurement Accuracy: Real Or Imagined



Specsmanship Example

System 1 Common Mode Rejection Ratio Spec.

60 dB + Gain In dB To 120 dB For Balanced Input And
110 dB For A 350 Ohm Source Unbalanced,
DC to 60 Hz.

System 2 Common Mode Rejection Ratio Spec.

130 dB

- Common Mode Rejection Ratio (CMRR) Depends On Common Mode Signal Frequency, Amplifier Gain, And Input Lead Balance.
- On The Surface, System 2 Would Seem Better.
- However, The Specification Indicates Nothing About How The Product Will Be Used In Your Facility.
- System 2's Spec Should Be Further Researched.
- **130 dB Is Most Likely Not The Level Of CMRR You Will Experience.**

Measurement Accuracy: Real Or Imagined



Total Measurement Error

- When The True Error Specifications Are Known.....

The Root Sum Square (RSS) Can Be Used To Calculate The Total Measurement Error Expected.

$$E_{\text{Total}} = \sqrt{\sum (E_N^2)}$$

Where

E_{Total} Is The Total Measurement Error.
 E_N Is The Error Associated With Element N of The Measurement.

Example:

Higher Than
Either Accuracy
(Not The Sum)

Transducer Accuracy +/- 1.0%
Measurement System Accuracy +/- 0.5%

$$E_{\text{Total}} = \text{SQRT}((0.01)^2 + (0.005)^2)$$

$$E_{\text{Total}} = 0.012 = 1.2\%$$

Measurement Accuracy: Real Or Imagined



Normalization & Site Specifics

- One Task You Must Not Overlook Is Error Source Normalization.
- Since Errors Are Treated As Percentages You Need To Ask...

Percentage of What?

- Percentage of Full Scale Range Is Typically Used In Specifications.
- However, Vendor To Vendor Full Scale Range Can Vary.
- Errors That Vary Due To Site Specifics (i.e. Temperature) Need To Take Into Account The Intended Environment.
- **Remember To Compare Apples To Apples.**

Measurement Accuracy: Real Or Imagined



Transducer Element Error

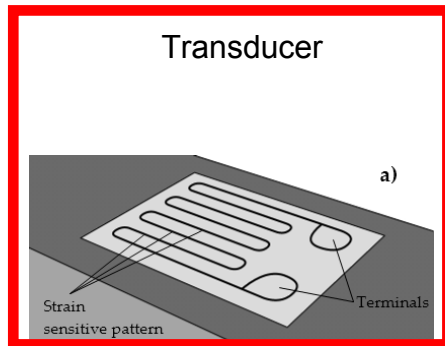

- Transducer Errors Depend On:
 - Transducer Type.
 - Measurement Environment.
 - Transducer Installation & Handling.
- **Transducer Error Defines The Best Measurement That Can Be Made With The Transducer.**

Measurement Accuracy: Real Or Imagined

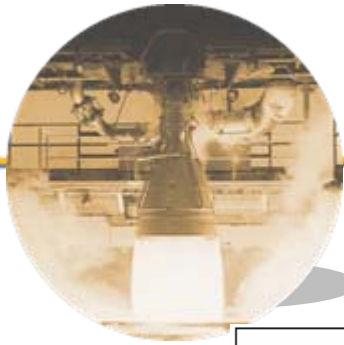

Pressure Transducer Error Example



Error Source	Accuracy Stated	Example Analysis	
		(Value)	(Percent)
		FSO	100 mV
		FS	50 PSI
		Acceleration	1 g
		Temperature Variation	10 °C
Combined Non-Linearity, Hysteresis And Repeatability	+/- 0.1 % FSO	(+/- 0.1 mV)	(+/- 0.1 %)
Acceleration Sensitivity	+/- 0.0015 % FS/g	(+/- 1.5 μ V)	(+/- 0.0015%)
Thermal Zero Shift	+/- 0.01 % FS/°C	(+/- 0.1 mV)	(+/- 0.1 %)
Thermal Sensitivity Shift	+/- 0.01 % FS/°C	(+/- 0.1 mV)	(+/- 0.1 %)
Root Sum Square			+/- 0.173 %

- This Pressure Transducer's **Typical** Measurement Error Is **0.173% of Full Scale**.
- The Value Accounts For 1g Of Acceleration And 10 °F Of Temperature Variation.
- Assuming The Temperature Variation And Acceleration Are Zero The Typical Measurement Error Would Be 0.1 %.
- **The Environmental Factors Almost Double The Error.**
- **This Error Can Not Be Calibrated Out.**

Measurement Accuracy: Real Or Imagined



Measurement System Errors

- The Measurement System Includes Many Parts.
- Each Part Can Contribute To The Measurement System Error.
- Some Parts Have Multiple Settings And Their Errors Will Depend On The Setting Used.
- Some Parts Will Not Be Used In Some Measurements.
- The Total Measurement System Error Is The RSS Of The Errors For The Parts Used At The Settings Used.
- Some Errors Will Be Nullified Using Calibration Standards.

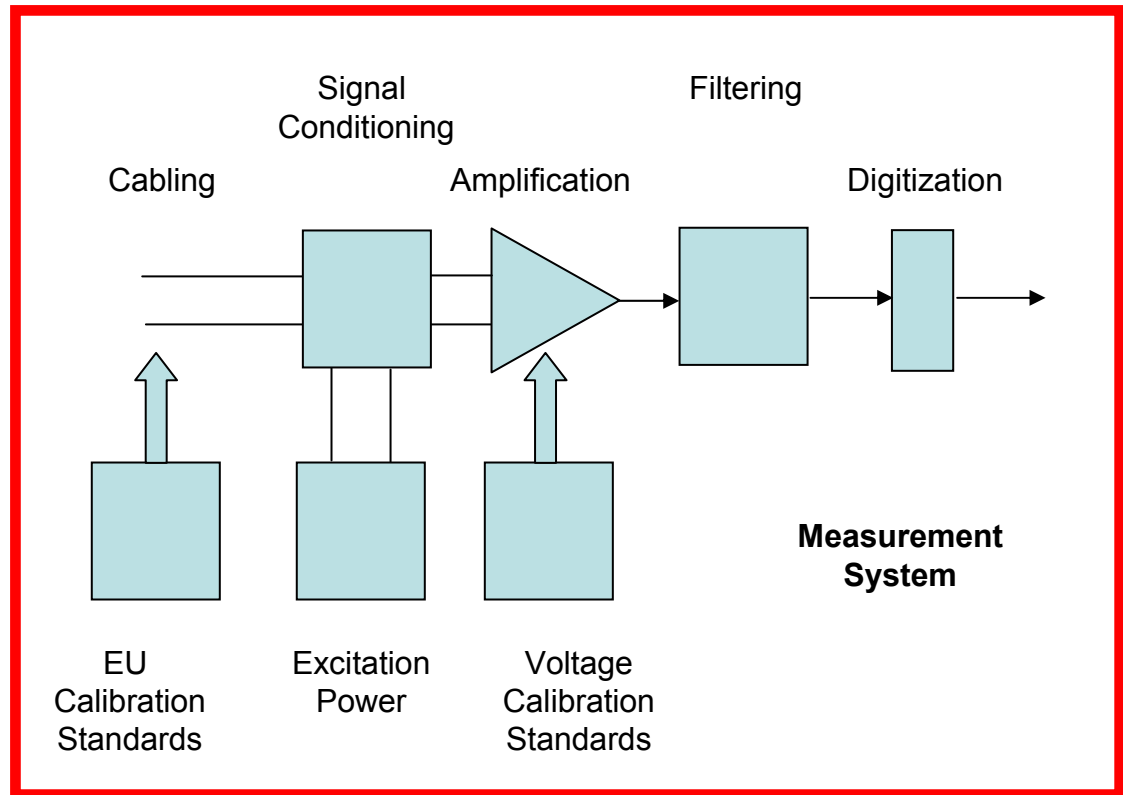

Measurement Accuracy: Real Or Imagined



Which Errors Must Be Considered?

- Data Conversion Method
 - Voltage Measured Indicates Engineering Unit (EU) Value.
 - Thermocouple Lookup
 - Transducer Datasheet
 - Must Ensure Voltage Measured Is Calibrated
 - Must Take Into Account Cable Losses
 - Must Ensure Excitation At Transducer Is Correct
 - In Situ (End To End) Calibration
 - Shunt Calibration
 - Controlled & Variable Environment
 - Must Ensure Calibration Stimuli
- Transducer Type
 - Is Signal Conditioning Used (e.g. Bridge Completion)?
 - Is Excitation Used?

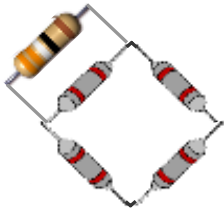

Measurement Accuracy: Real Or Imagined

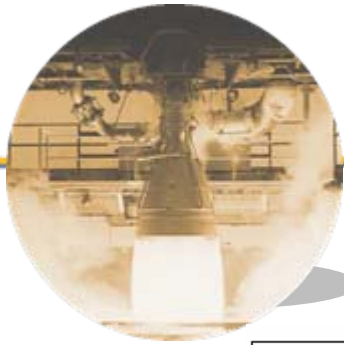

Excitation Error



Error Source	Accuracy Stated	Example Analysis	
		Setting	10 V
		Days	30
		Temperature Variation	2 °C
		(Value) (Percent)	
Excitation Level	+/- 0.1 % of Setting	(+/- 10 mV) (+/- 0.1 %)	
Regulation	+/- 0.01 % of Setting	(+/- 1 mV) (+/- 0.01 %)	
Stability	+/- 0.01 % of Setting For 30 Days	(+/- 1 mV) (+/- 0.01 %)	
Temperature Coefficient	+/- 0.005 % of Setting Per °C	(+/- 1 mV) (+/- 0.01 %)	
Noise	200 μ V peak to peak	(+/- 100 μ V) (+/- 0.001 %)	
Root Sum Square		(+/- 0.101 %)	
RSS Using End To End Calibration	Remove Excitation Level Spec.	(+/- 0.017 %)	

- Excitation Errors Affect Transducers That Require Excitation Voltage Or Current.
- The Level Error Specification Can Be Ignored If End To End EU Calibration Is Used.
- Excitation Error Can Be Ignored If Excitation Is Not Being Used.
- Implicit To The Error Specification Is The Requirement That Each Channel Has An Individual Regulation Circuit.
- Without Individual Regulation Excitation Error Can Become Huge Due To Shorted Or Open Transducers Affecting Each Other.

Measurement Accuracy: Real Or Imagined



Do Not Fall Prey To This

Group Regulation

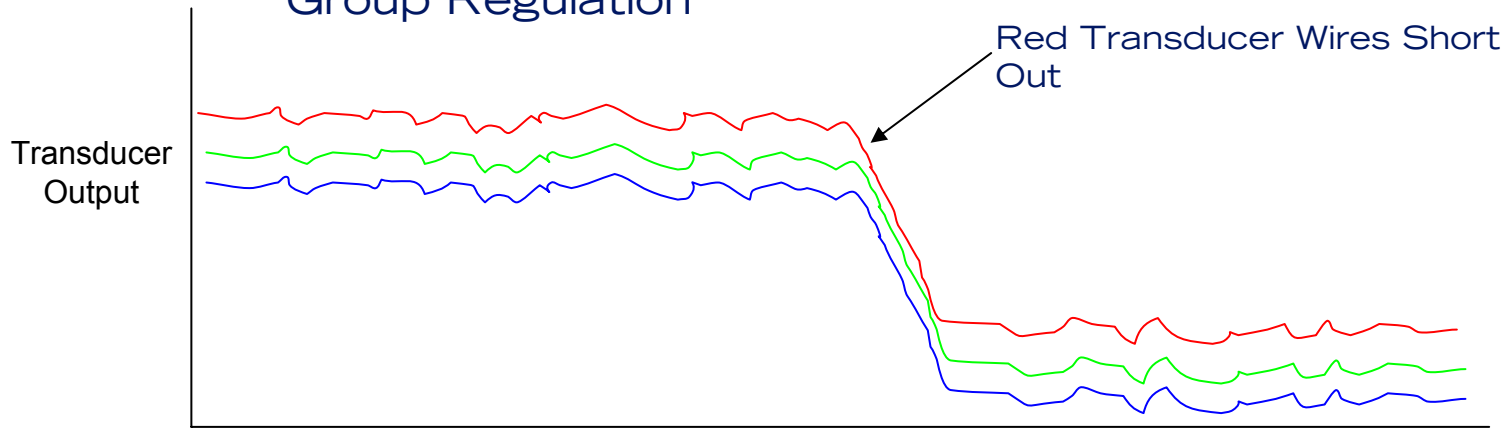

Individual Regulation

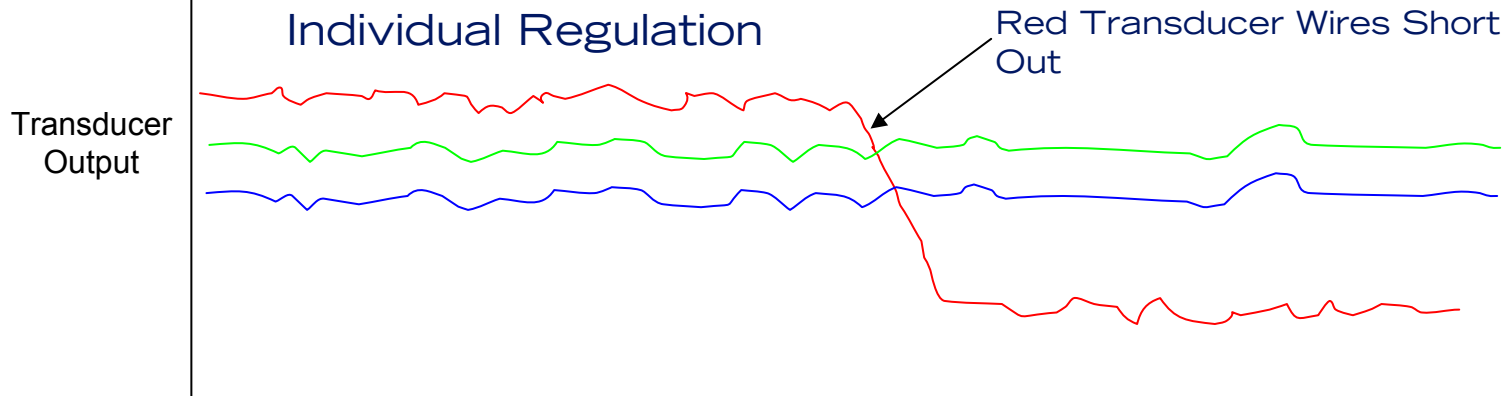

Measurement Accuracy: Real Or Imagined

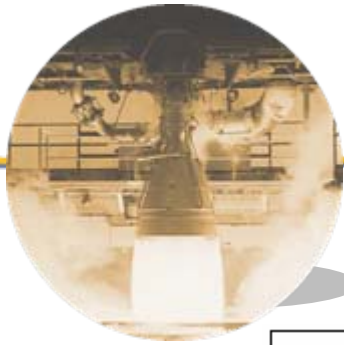

Signal Conditioning Error



Error Source	Accuracy Stated	Example Analysis	
		Balance Range	12.5 mV
		Hours	8
		Temperature Variation	2 °C
		Completion Value	120 Ω
		Excitation	5 V
		Max Bridge Output	100 mV (10 Ω)
		(Value) (Percent of Measurement)	
Bridge Balance Accuracy	+/- 0.05 % of Range	(+/- 6.25 μV) (+/- 0.00625 %)	
Bridge Balance Stability	+/- 0.02 % of Range For 8 Hours	(+/- 2.5 μV) (+/- 0.0025 %)	
Bridge Balance Temp. Coefficient	+/- 0.005 % of Range Per °C	(+/- 1.25 μV) (+/- 0.00125 %)	
Completion Resistor Temp. Coefficient	+/- 0.0001 % of Value Per °C (i.e. 1ppm)	(+/- 240 μΩ = +/- 2.5 μV) (+/- 0.0025 %)	
Root Sum Square		(+/- 0.007 %)	
Total If Using End To End Calibration	Remove Balance Accuracy	(+/- 0.0037%)	

- Signal Conditioning Errors Affect Bridge Measurements.
- The Balance Error Specification Can Be Ignored If End To End EU Calibration Is Used.
- Signal Conditioning Includes Bridge Completion, Bridge Balance, & Possibly Others.
- Different Assumptions Will Lead To Different RSS Numbers
- Assumptions Depend On Your Testing Requirements.

Measurement Accuracy: Real Or Imagined

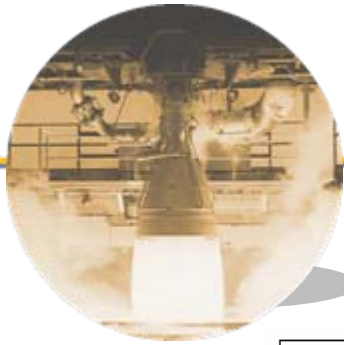

Amplification & Filtering Error

Site Specifics

Error Source	Accuracy Stated	Example Analysis	
		FS Input	2 mV, G = 5000
		Temperature Variation	2 °C
		(Value) (Percent)	
Gain Stability	+/- 0.02 % of FS Input for 30 Days	(+/- 0.0004 mV) (+/- 0.02 %)	
Gain Temperature Coefficient	+/- 0.005 % of FS Input Per °C	(+/- 200 nV) (+/- 0.01 %)	
Accuracy	+/- 0.02 % of FS Input (Gain >= 1k)	(+/- 0.0004 mV) (+/- 0.02 %)	
CMRR	60 dB Plus Gain In dB Up to 130 dB	(130 dB) (+/- 0.25 µV) (+/- 0.0125 %)	
Zero Accuracy	+/- 2 uV RTI	(+/- 2 µV) (+/- 0.1%)	
Zero Stability	+/- 1 uV Per °C	(+/- 2 µV) (+/- 0.1%)	
Noise	+/- 60 nV (Filtered Fco = 10 Hz)	(+/- 60 nV) (+/- 0.003%)	
Root Sum Square		+/- 0.145 %	
RSS Using Voltage Calibration Or End To End Calibration	Reduce Zero Accuracy Spec And Linearity Spec.	+/- 0.103 %	

- Amplification Errors Are Worst At Highest Gain
- The Zero Accuracy & Linearity Error Specifications Can Be Reduced By Using End To End EU Calibration Or Voltage Calibration.
- CMRR Is Normalized Into A Value Using $CMRR = 20 \log_{10}(\text{Gain}/\text{CM Gain})$ And $V_{out} = \frac{1}{2} \text{CMGain} * (\text{Voltage Measured})$. Example Assumes Measurement Is FS Input.
- Assumptions Depend On Your Testing Requirements.

Measurement Accuracy: Real Or Imagined



Digitization Error 16 Bit SAR

Site Specifics

Error Source	Accuracy Stated	Example Analysis	
		FS Input	2 mV, G = 5000
		ENOB	14.25
		(Value) (Percent)	
Measurement Resolution 16 Bit SAR	+/- 102 nV	(+/- 102 nV)	(+/- 0.0051 %)
Linearity	+/- 0.004 %	(+/- 80 nV)	(+/- 0.004 %)
Root Sum Square			(+/- 0.0065 %)
RSS Using Voltage Calibration Or End To End Calibration			(+/- 0.0051 %)

- Reference IMAC 2008 Presentation
- 16 Bit SAR Used With High Gain (5000) Provides 9781 Effective Codes Per mV Measured.
- This Error Collection Is Normalized To 2 mV Full Scale Measurement & Matches The Normalization Used In Determining Amplification & Filtering Error.

Measurement Accuracy: Real Or Imagined



Digitization Error 24 Bit $\Sigma\Delta$

Site Specifics

Error Source	Accuracy Stated	Example Analysis	
		Value	Percent
		FS Input	163.84 mV G = 62.5
		ENOB	16.72
		Measurement Level	2 mV
		(Value) (Percent)	
Measurement Resolution 24 Bit $\Sigma\Delta$	+/- 5.9 μ V	(+/- 5.9 μ V)	(+/- 0.29 %)
Linearity	+/- 0.004 %	(+/- 6.4 μ V)	(+/- 0.32 %)
Root Sum Square		(+/- 0.43 %)	
RSS Using Voltage Calibration Or End To End Calibration		(+/- 0.29 %)	

- Reference IMAC 2008 Presentation
- 24 Bit $\Sigma\Delta$ Has Much Lower ENOB Due To SINAD Numbers For Conversion Technique.
- This Error Collection Is Normalized To 2 mV So That The Higher Gain Product (SAR) Can Be Properly Compared.
- Coupled With Lower Gain (Typical Of $\Sigma\Delta$ Offerings) Leads To Worse Error Numbers When Considering Level To Measure.

Measurement Accuracy: Real Or Imagined



Always Keep This In Mind



+

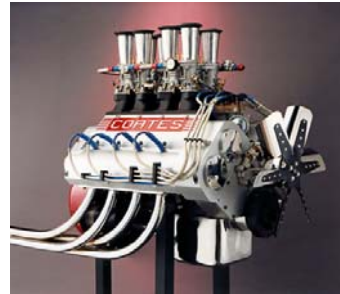

≠



- No Single Element Of A Measurement System Will Optimize Measurements.
- All Elements Play A Part In Measurement System Accuracy.
- Element Worth Depends On What You Intend To Measure And How You Intend To Use The Element.

Measurement Accuracy: Real Or Imagined



Cabling Error

- Every Connection Point Along The Path From Amplifier To Transducer Creates An Electromotive Force (EMF).
- EMF's Add Errors. These Errors Can Be Due To Plug On Modules The Measurement System Uses To Allow Customization Of A Standard Input Module And Save \$\$.
- Source Currents In The Amplifiers Cause Errors Also When They Work Against Slight Mismatches In Resistances Along The Way To The Transducer.
- Can Be As High As +/- 0.1 % At High Gain (Low Level Measurement 2 mV FS)

Influenced By You

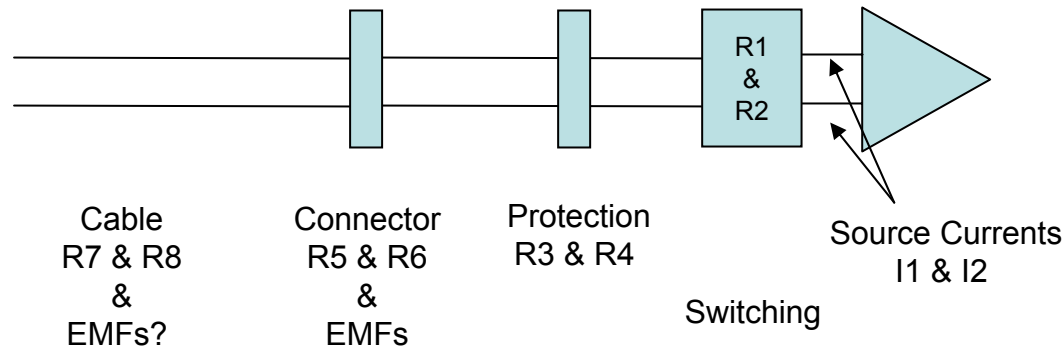

(I1 \neq I2)
(R1 \neq R2), (R3 \neq R4), (R5 \neq R6), (R7 \neq R8)

Measurement Accuracy: Real Or Imagined



Summing Up Measurement System Errors

Error Source	Accuracy Stated Without Calibration	Accuracy With Calibration Assuming No Calibration Error
Excitation	+/- 0.101 %	+/- 0.017 %
Amplification & Filtering	+/- 0.145 %	+/- 0.103 %
Signal Conditioning	+/- 0.007 %	+/- 0.0037 %
Cabling	+/- 0.1 %	+/- 0%
Digitization	+/- 0.0065 %	+/- 0.0051 %
Root Sum Square	+/- 0.2033 %	+/- 0.1046 %

- Assessment For 2 mV FS Measurement At High Gain
- This Assumes All Errors Come Into Play (Not Generally The Case)
- Calibration Brings The Error Down Significantly
- Remember, The Transducer Was +/- 0.173 %
- The Combined RSS (Calibrated) Is +/- 0.202 % Indicating The Transducer Is A Strong Controlling Element Here.
- Calibration Errors Do Need To Be Derived And Included.

Measurement Accuracy: Real Or Imagined

Voltage Calibration Issues To Watch

(I1 ≠ I2)
(R1 ≠ R2), (R3 ≠ R4), (R5 ≠ R6), (R7 ≠ R8), (R9 ≠ R10)

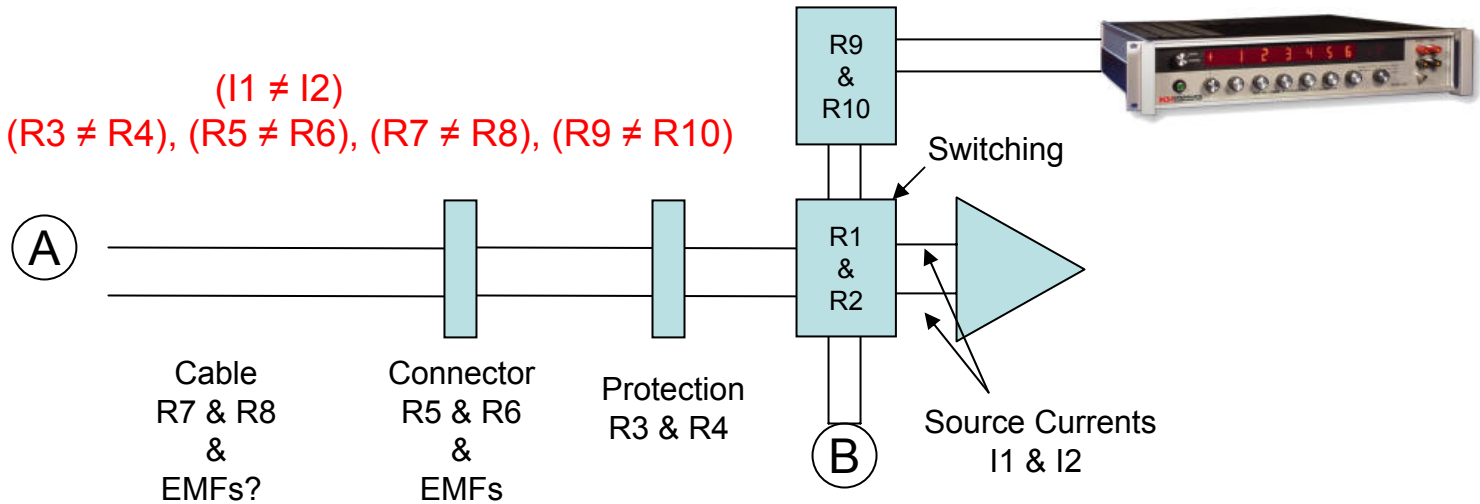

- Voltage Calibration Electrical Path Difference Manifests In Offset Errors When Compared To Point A Or Point B.
- Characterizing The Difference Between A and B Allows For Removal Of All Source Current Affects.
- This Typical Voltage Calibration Arrangement Will Not Lead To Great Absolute Level Indications If A and B Are Not Characterized.
- It Is, However, Very Useful In Eliminating Slope (Gain) Errors.

Measurement Accuracy: Real Or Imagined



Trusting Calibration

- Calibration Sources Must Be Calibrated By Metrology Labs
- Calibration Data Must Be Checked For
 - Hysteresis Errors
 - Noise Errors
 - Linearity Errors
 - Flat Line Errors
 - Overload Errors

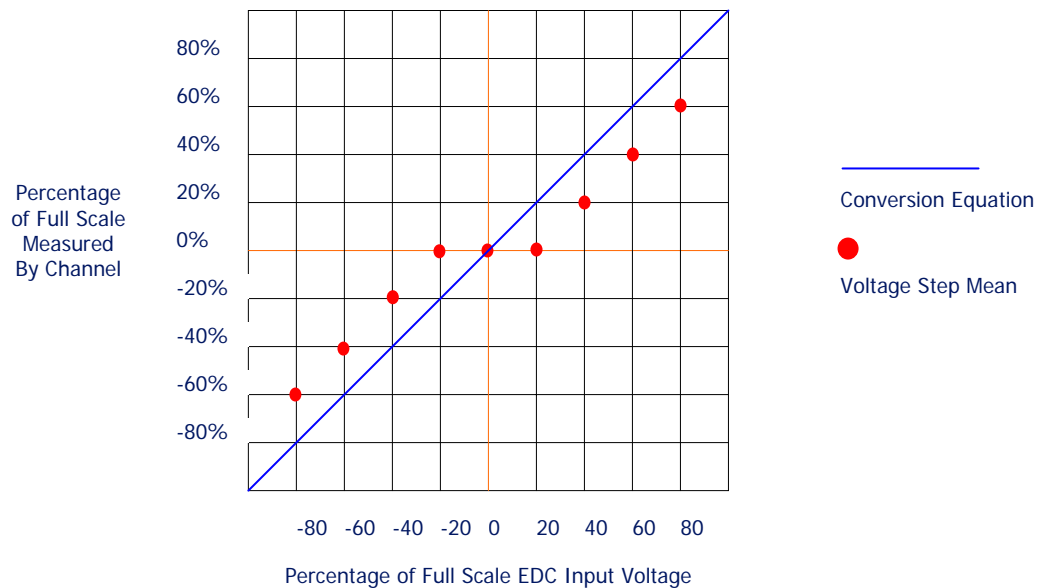

Measurement Accuracy: Real Or Imagined



Trusting Specifications



- ❑ Calibration and Test Data Reports
- ❑ Detailed report including pass/fail criteria
 - Gain accuracy (all outputs)
 - Linearity (all outputs)
 - Zero accuracy (all outputs)
 - Bandwidth (all outputs)
 - Filter response
 - Noise (all outputs)
 - Common mode (350 Ohm)
 - Source current
 - Cal attenuator accuracy
 - Current exc. accuracy & regulation
 - Voltage exc. accuracy & regulation
 - Voltage monitor accuracy
 - Bridge completion function
 - Autobalance accuracy
 - Shunt calibration accuracy
- ❑ Final System Test Report

You
Should Ask
For This
Information

Measurement Accuracy: Real Or Imagined



Concluding Remarks

- No Single Element Of A Measurement System Will Optimize Measurements.
- You Need To Understand How The Specifications Affect Your Testing.
- The Transducer Will Have A Large Affect On Measurement Accuracy Since It's Environment Is Not Generally Controlled.
- Measurement System Environment Needs To Be Taken Into Account.
- If A Specification Is Missing Or Obtuse Ask For Clarification.
- If The System Performs Better Than Specifications Indicate Then You Have Found A Good Vendor.
- If The System Performs Worse Than Expected Either You Are Not Using It Correctly, You Have Interpreted The Specifications Wrongly, Or You Are A Victim Of SpecsmanSHIP.
- Good Software Can Help, But It Does Not Make Up For Poor Transducers Or Poor Measurement System Hardware.

