



MEGGITT

smart engineering for
extreme environments

Variable Capacitance (VC) Accelerometers

Why VC accelerometers

How they differ from piezoelectric and
piezoresistive accelerometers

The information contained in this document is the property of Endevco Corporation and is confidential and/or copyright material. This information and this document may not be used without the express authorization of Endevco. Any unauthorized use or disclosure may be unlawful.

Variable Capacitance (VC) Effect

Theory of operation:

Changes in capacitance due to capacitive plate movements are proportional to acceleration

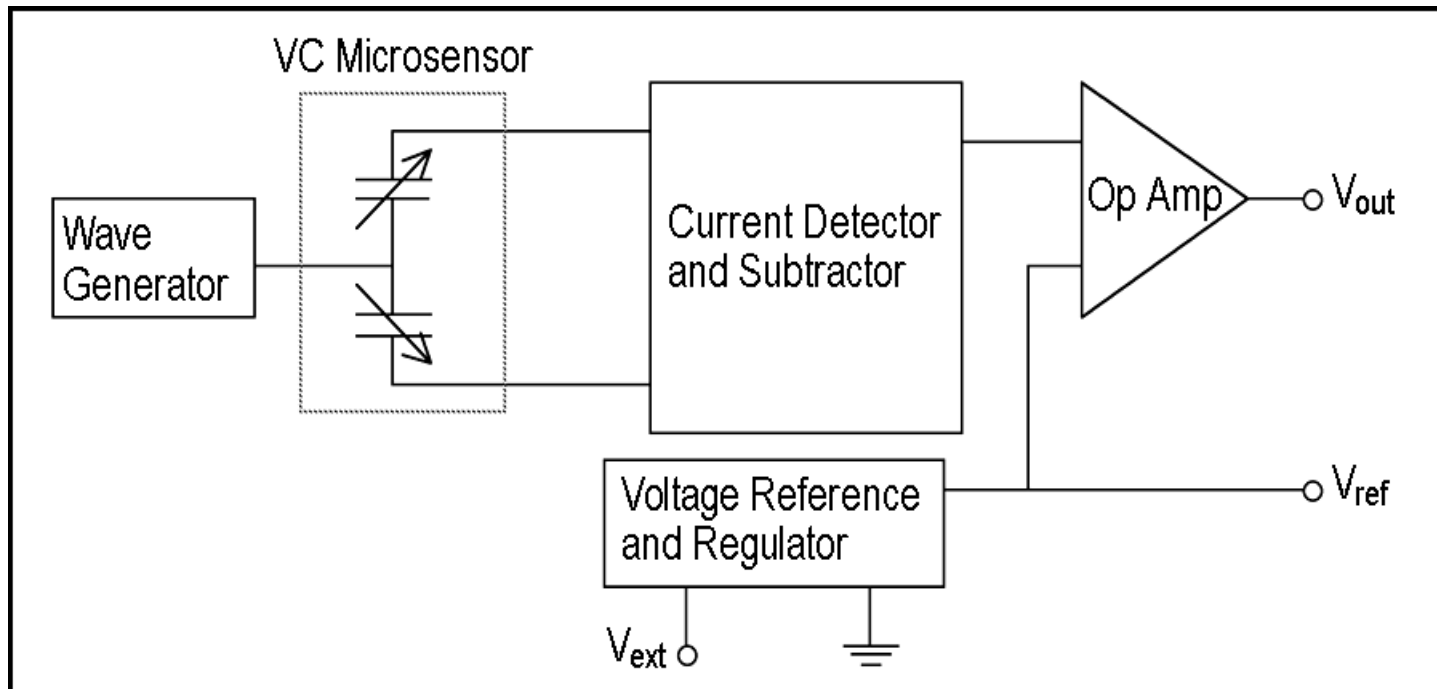

Variable Capacitance Sensor

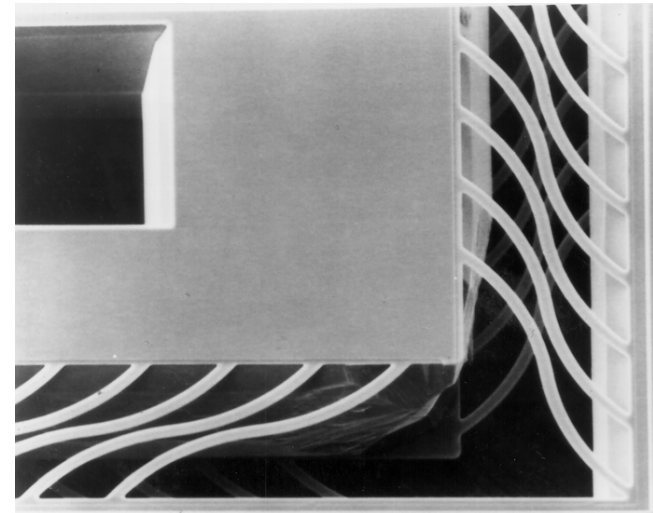
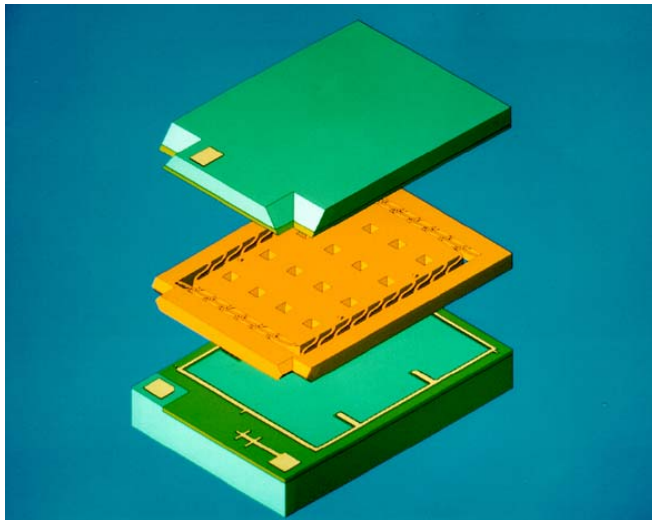

Three Layers Wafer Anodically Bonded Together
Inertial Mass in Center Layer
Microsensor Size, 2 mm x 2.8 mm x 0.9 mm

Variable Capacitance Accelerometers

7290A



7293A



7296A



7292



Actual size

- Low-g
- EMI protection
- Electronic Temp. Compensation
- Hermetic Sealing

VC Characteristics

- ▶ Frequency response is down to DC
- ▶ DC Power is required (Typically 10.0 Vdc)
- ▶ Greater output at low g levels than a PR Device
- ▶ Limited high frequency response compared to PR Device
- ▶ Same signal conditioning as a full, four wire Wheatstone Bridge sensor
- ▶ Frequently used in “Flight Test” applications for high output voltage at low level g applications

Some VC Specifications

- Thermal Sensitivity Shift: +/- 1.5% from -67°F to 257°F (-55°C to 125°C)
- Thermal Zero Shift: +/- 1.5% Full Scale Output from -67°F to 257°F (-55°C to 125°C)
- Wide excitation voltage range 8.0 to 30.0 Vdc
- Gas Damping – ratio change 0.04%/°F (0.08%/°C)
- Ranges from +/- 2g to +/- 150g full scale
- High shock survivability
- Micro g resolution; nano g resolution available with large IEPE

second order
characteristic

Second Order Characteristic

Frequency (Hz)

natural frequency 3000 Hz
damping 0.70 ratio
scale freq 1.426 multiplier

freq (Hz)	amp (dB)	amp (%)	phase (deg)
1	0.0	0%	0
1	0.0	0%	0
2	0.0	0%	0
3	0.0	0%	0
4	0.0	0%	0
6	0.0	0%	0
8	0.0	0%	0
12	0.0	0%	0
17	0.0	0%	0
24	0.0	0%	1
35	0.0	0%	1
50	0.0	0%	1
71	0.0	0%	2
101	0.0	0%	3
144	0.0	0%	4
205	0.0	0%	5
292	0.0	0%	8
417	0.0	0%	11
594	0.0	0%	16
848	0.0	0%	23
1,209	-0.1	-1%	34
1,724	-0.4	-4%	50
2,458	-1.5	-16%	74
3,505	-4.5	-40%	-77
4,999	-9.3	-66%	-53
7,128	-15.1	-82%	-36
10,165	-21.2	-91%	-24

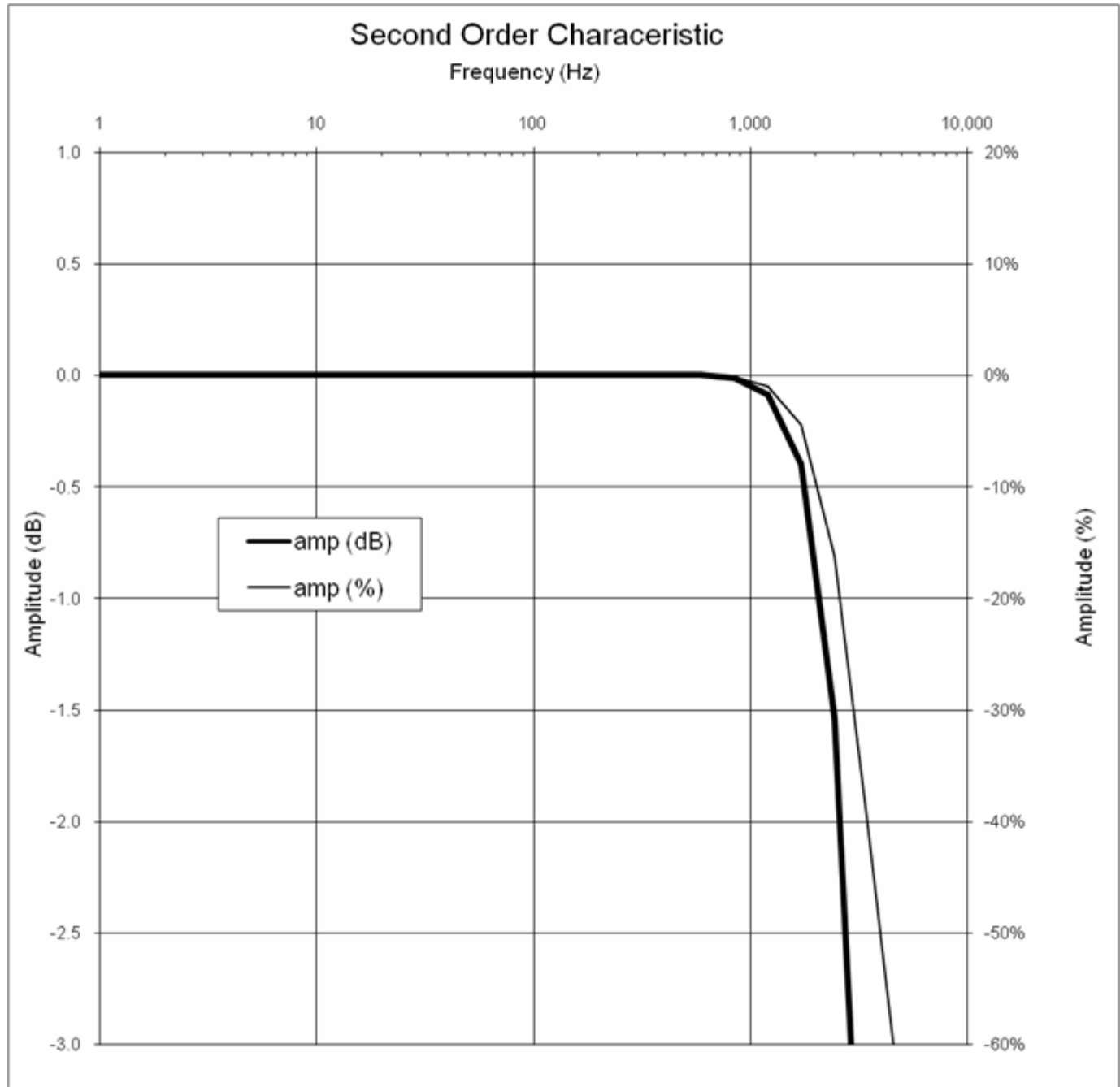

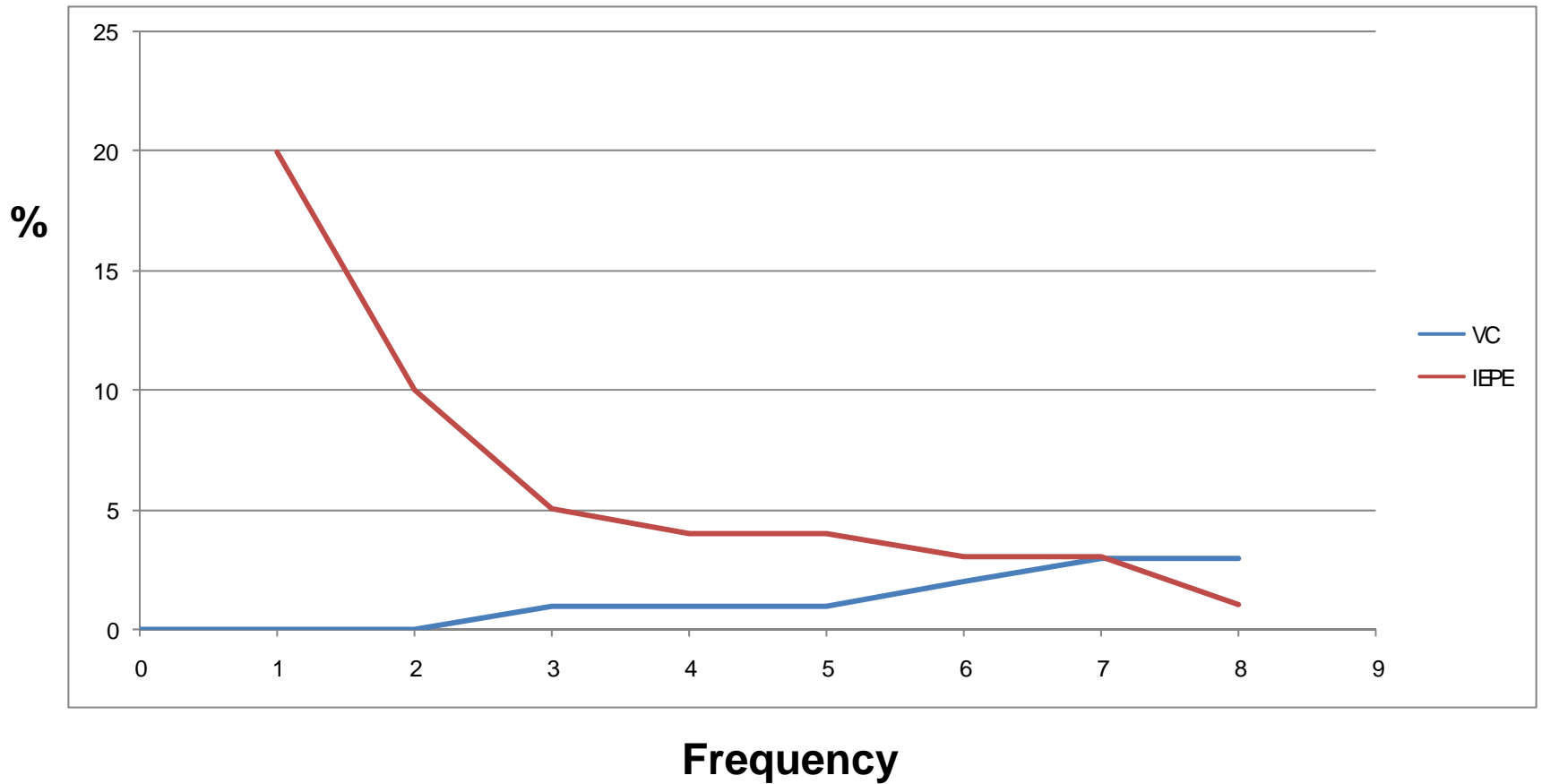

Phase Comparison VC vs. IEPE Accelerometer

Where are they used?

- ▶ Vehicle ride studies
- ▶ Elevators and amusement park rides
- ▶ Flutter testing
- ▶ Railroad testing and control
- ▶ Robotics
- ▶ Tilt measurement
- ▶ Low frequency vibration and modal analysis

Some Important Terms (VC)

- ▶ ZMO: “Zero measurand output” DC bias voltage present with no input signal
- ▶ TZS: “Thermal zero shift” . The amount of zero drift, in mV, over a specified temperature range
- ▶ TSS: “Thermal sensitivity shift” The % change in sensitivity over a specified temperature range
- ▶ Excitation Voltage: The supply voltage applied to the sensor



MEGGITT

smart engineering for
extreme environments

Confidentiality agreement

The information contained in this document is the property of Endevco Corporation and is confidential and/or copyright material. This information and this document may not be used or disclosed without the express authorization of Endevco. Any unauthorized use or disclosure may be unlawful. The information contained in this document may be subject to the provisions of the Export Administration Act of 1979 (50 USC 2401-2420), the Export Administration Regulations promulgated hereunder (15 CFR 730-744), and the International Traffic in Arms Regulations (22 CFR 120-130). The recipient acknowledges that these statutes and regulations impose restrictions on import, export, re-export and transfer to third countries of certain categories of data, technical services and information, and that licenses from the US Department of State and/or the US Department of Commerce may be required before such data, technical services and information can be disclosed. By accepting this document, the recipient agrees to comply with all applicable governmental regulations as they relate to the import, export and re-export of information.